

General Features

- ▶ High corrosion resistant performance: Pb-Ca multi-alloy grid
- ▶ High energy density and power density
- ▶ Optimized capability of instant high-current discharging
- ▶ Excellent charge acceptance ability
- ▶ Strong high and low temperature performance
- ▶ Low self-discharge rate



6EVF110
VRLA AGM DEEPCYCLE SLI BATTERY
UN2800 NON-SPILLABLE BATTERY

Dimension: 330(L) × 172(W) × 214(H) × 214(TH)

Unit: mm

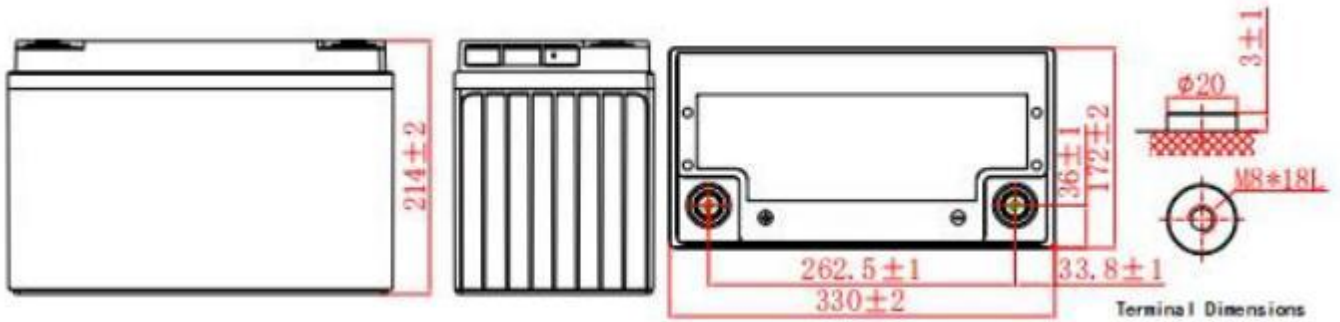

Specification	
Nominal Voltage	12V
Nominal Capacity	110AhC3 / 132AhC20
Design life	5 years
Terminal	M8
Approx. Weight	Approx 32.5kg \pm 3% (71.65lbs)
Container Material	ABS
Self discharge	3% of capacity declined per month at 25°C
Rated Capacity	
20Hour Rate (6.60A to 10.5V)	132.0Ah
3Hour Rate (36.7A to 10.5V)	110.0Ah
1Hour Rate (90.0A to 10.5V)	90.0Ah
Operating Temperature	
Discharge:	-20 ~50°C (-4~ 122°F)
Charge :	-20 ~50°C (-4~ 122°F)
Storage:	-20 ~50°C (-4~ 122°F)
Charge Method(25 °C)	
Max charge current	16.5A
Float Use:	13.7-13.9V@25
Cycle Use :	14.7-14.9V,@25

Standards

Executive standard :GB/T32620-2016

Applications

- ▶ Electric vehicle
- ▶ Electric wheelchair
- ▶ Electric scooter
- ▶ Electric play car for children
- ▶ Garbage truck
- ▶ Patrol car

Attain Certificate



Discharge characteristic

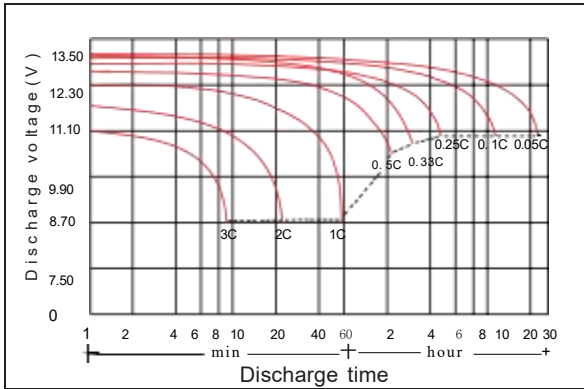

Charging characteristic

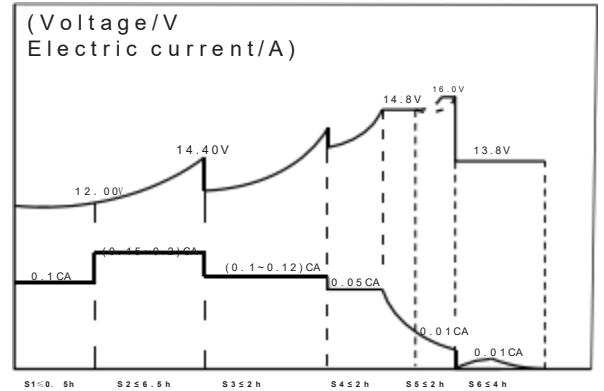

The effect of temperature on capacity

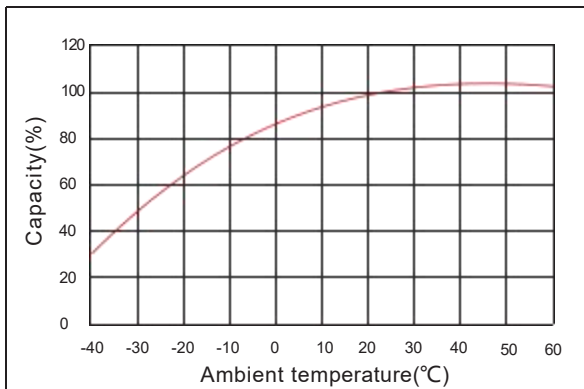

The effect of discharge depth on cycle life

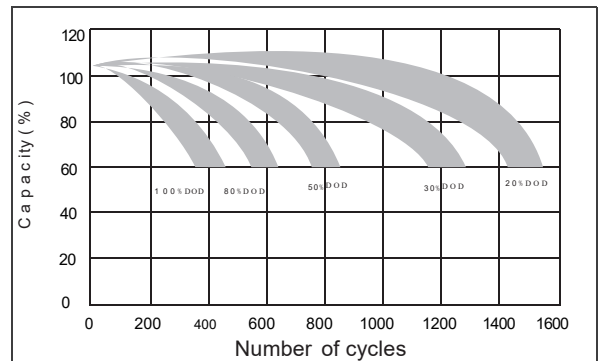

Constant Current Discharge Characteristics Unit:A (25°C,77°F)

FV/Time	30min	1h	2h	3h	5h	8h	10h	20h
1.60V	164	92.6	49.4	38.1	23.7	15.0	12.7	6.70
1.65V	160	92.0	49.1	37.8	23.6	14.9	12.5	6.67
1.70V	157	91.4	48.7	37.2	23.3	14.7	12.4	6.63
1.75V	156	90.0	48.0	36.7	23.0	14.6	12.3	6.60
1.80V	149	87.7	47.1	36.5	22.4	14.6	12.2	6.57
1.85V	136	81.3	44.7	34.4	21.3	13.9	11.8	6.45

Constant Power Discharge Characteristics Unit: W/cell (25°C ,77°F)

FV/Time	30min	1h	2h	3h	5h	8h	10h	20h
1.60V	296	176	93.3	72.5	45.0	29.2	24.4	13.3
1.65V	293	174	93.0	71.6	44.7	29.0	24.1	13.2
1.70V	293	173	92.7	71.1	44.5	28.8	23.8	13.1
1.75V	291	171	92.2	70.7	44.2	28.7	23.7	13.1
1.80V	283	170	91.9	70.5	43.6	28.4	23.4	13.0
1.85V	259	157	87.8	67.1	41.7	27.5	23.0	12.9



Instructies met betrekking tot levering, montage, gebruik-, onderhoud- en opslag van AxiWin AGM accu's

AxiWin nog de verdeler van het gekochte AxiWin AGM product kan niet aansprakelijk worden gesteld voor problemen met de geleverde accu's als gevolg van het niet juist naleven van alle verstrekte instructies!

Montage:

Sluit de accu alleen aan indien u verstand heeft van elektronica. Laat uitsluitend deskundig en gekwalificeerd personeel de gekochte accu aansluiten en of vervangen! Wij verlenen dan ook geen garantie voor gevolgschade als gevolg van onjuist, ondeskundig en oneigenlijk gebruik. Laat u ALTIJD goed informeren en leef alle vermelde instructies na (Ook de instructies uit het met het voertuig / de machine bijgeleverde instructies en het bijbehorende MSDS (Material Safety Datasheet). Voorkom kortsluiting, werk veilig en vooral nauwkeurig! De meeste AxiWin accu's zijn gevarengood (UN2800). Bij verkeerd en onjuist gebruik kan een accu exploderen. Gebruik altijd (zuur)beschermende kleding en draag een beschermingsbril wanneer u met of aan een accu werkt.

Laden:

Laadt de accu uitsluitend met een goede, veilige en gekeurde lader. Een lader moet altijd op de AGM stand ingesteld worden (zie de juiste parameters op het bijgevoegde datasheet. De accu **NOOIT** laden in een geheel afgesloten ruimte. Zorg altijd voor een goed geventileerde ruimte waar roken en vuur strikt verboden is! Blijf van alle kabels af wanneer er geladen wordt. Mocht u toch aan de accu of lader moeten komen zorg dan dat de lader altijd uitgeschakeld is. Voorkom daarnaast altijd vuur, vonkvorming, kortsluiting en wrijving rondom en in de omgeving van een accu! Zorg ervoor dat de accu goed onderhouden is en een niet te lage spanning. Op tijd en goed laden is dus het devies en zorg er daarnaast voor dat de poolaansluiting(en) altijd goed "vast" zitten.

- De laadspanning van de lader mag **NOOIT** hoger zijn dan 15V en moet minimaal 14,5 tot 14,9 Volt bedragen. Wanneer een AxiWin accu volledig geladen is moet de lader **ALTIJD** naar een floatspanning gaan van 13,2 tot 13,5 Volt. Controleer deze spanningen ook!
- Voelt de accu heet aan, verspreidt deze een ongewone geur dan het laden onmiddellijk stoppen. Ook wanneer de accu van vorm verandert, of wanneer er iets anders abnormaals gebeurt het laden direct stoppen. De accu eerst laten afkoelen en (ook bij twijfel). **NOOIT** verder laden en direct deskundig en gekwalificeerd personeel raadplegen!
- Na het laden, de accu 1 tot 2 uur laten rusten alvorens de spanning te meten. Bedraagt de spanning minder dan 12,4V dan extra bijladen. Een accu is volledig geladen wanneer de spanning in rust 12,8 Volt bedraagt.
- Ontlaad de accu nooit tot onder de 12 Volt. Weet dat een accu onder de 11.75V geheel ontladen is. Zorg dus dat de accu na gebruik altijd direct weer goed en veilig geladen wordt. Beneden de 10 Volt is de accu dusdanig ontladen dat de garantie **NIET** meer kan worden toegekend. Zorg er dus voor dat de accu altijd goed geladen is en blijft. Overigens zullen de meeste laders de lading beneden de 7 Volt niet eens meer oppakken.

Stalling en onderhoud:

- Vóór opslag dient de accu 100% geladen te zijn. Ontkoppel vervolgens de accu en sla de accu op in een schone, droge en goed geventileerde ruimte op bij ca 18 graden. Voorkom elk contact met bijtende producten en stel de accu **NOOIT** bloot aan warmte, wrijving, druk en/of vuur.
- Bij opslag dient de accu regelmatig gecontroleerd te worden op spanning en indien nodig geladen te worden (telkens wanneer de klemspanning minder dan 12,4V bedraagt). Bij onjuiste lading /ontlading zal de accu defect gaan. Er zal sulfaat in de accu ontstaan welke ervoor zorgt dat de accu zijn stroom niet meer kan vasthouden. Sulfatering valt niet onder garantie! Zorg er dus voor dat de accu altijd goed geladen is en blijft!
- Indien u kiest voor een druppellader of zonnepaneel zorg er dan voor dat de lader **ALTIJD** aangesloten blijft en ook op de juiste AGM instelling staat. Wanneer accu volledig geladen is dient de lader of het zonnepaneel automatisch naar de juiste floatspanning te gaan en op het moment dat het nodig is moet het ook weer automatisch gaan laden. Zorg ervoor dat er altijd meer stroom in de accu gaat dan dat er uitgaat. Ondanks dat een AxiWin accu op een lader of zonnepaneel staat kan deze ontladen doordat er bijvoorbeeld een lekstroom of verbruiker aanwezig is. Een zonnepaneel laadt bijvoorbeeld niet wanneer de zon niet schijnt en zo zou er meer stroom uit kunnen gaan dan er binnen komt.

Transport:

- De meeste loodaccu's zijn gevarengood (UN2794 of UN2800). Werk daarom veilig volgens de instructies en volgens de MSDS (material safety datasheet).
- De accu dient goed verpakt te worden. De polen zullen geïsoleerd moeten worden om kortsluiting te voorkomen. Daarnaast moet een accu altijd vaststaan zodat deze niet kan omvallen en of beschadigen.
- Een accu dient met zorg te worden behandeld. De accu niet gooien of schokken en ook stoten vermijden. Een AxiWin accu nooit op z'n kop leggen of monteren.
- Nooit accu's samen met ontvlambare, explosieve stoffen of met scherpe metalen voorwerpen vervoeren.

AxiWin

Vervolg instructies met betrekking tot levering, montage, gebruik-, onderhoud- en opslag van AxiWin AGM accu's.

AxiWin nog de verdeler van het gekochte AxiWin AGM product kan niet aansprakelijk worden gesteld voor problemen met de geleverde accu's als gevolg van het niet juist naleven van alle verstrekte instructies!

Afvoer accu's:

Denk SVP aan het milieu! AxiWin AGM accu's worden 100% gerecycled en dienen volgens de geldende milieuwetgeving te worden afgevoerd. U mag de accu's altijd afgeven bij ons in het Magazijn of bij een milieu depot van uw gemeente. Wist u dat u zelfs wat geld krijgt voor het lood in een AxiWin accu wanneer u deze zelf inlevert bij een metaalverwerkingsbedrijf?

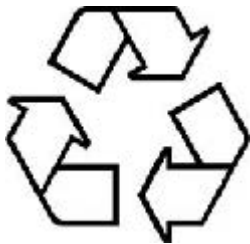

Verder:

- Nooit de accu onderdompelen in water of deze vochtig laten worden.
- Nooit de accu in de buurt van vuur en/of warmtebronnen bewaren.
- Nooit de positieve (+) batterijklem omwisselen met de negatieve (-) klem.
- Nooit de accu rechtstreeks aansluiten op een wandstopcontact.
- Nooit de accu in vuur gooien of blootstellen aan een directe warmtebron.
- Nooit de accu kortsluiten door kabels en/of andere metalen aan te sluiten op de positieve (+) en negatieve (-) klemmen/accupolen.
- Nooit de behuizing van de accu doorprikken met een nagel of eender welk ander scherp voorwerp; nooit proberen de accu open te breken of erop te stappen.
- Nooit op de accu slaan of er mee gooien verder nooit blootstellen aan harde schokken en/of stoten. De accu nooit op z'n kop leggen en/of monteren.
- Nooit rechtstreeks op of aan de accuklemmen lassen. Ook niet lassen in de omgeving van een accu.
- Nooit een poging ondernemen om de accu uit elkaar te halen of er wijzigingen op of aan te brengen.
- Nooit de accu in een magnetron/microgolfoven of in een drukvat leggen.
- Nooit de accu in contact laten komen met bijtende of scherpe producten.
- Nooit de accu samen met andere accu's typen/soorten/merken gebruiken. Zeker niet met andere soorten accu zoals droge-cel accu's, maar ook niet met accu's die een verschillende capaciteit hebben, andere productiedatum of van een ander type of merk zijn.
- Nooit de accu gebruiken wanneer deze een ongewone geur verspreidt, warm aanvoelt, van kleur of van vorm verandert, of wanneer er iets anders abnormaals gebeurt. Wanneer het bovenstaande zich voordoet tijdens het gebruik of het opladen van de accu, deze onmiddellijk uit het toestel verwijderen of loskoppelen van de lader en de accu niet langer meer gebruiken. Raadpleeg vervolgens altijd DIRECT deskundig personeel.
- Omgevingstemperaturen kunnen de werking van de accu negatief beïnvloeden. Raadpleeg altijd deskundig en gekwalificeerd personeel bij twijfel over te hoge of te lage temperaturen.
- De AxiWin AGM accu is in de fabriek hermetisch afgesloten u mag deze dan ook NOOIT proberen om de accu te openen! De garantie vervalt DIRECT bij het openen van een gesloten onderhoudsvrije accu AxiWin AGM accu.

Garantie:

Op een AxiWin AGM type SA & SB zit een garantie van 1 jaar en dan uitsluitend op fabrieks en constructiefouten. Op een AxiWin AGM type DC zit een garantie van 2 jaar en hier ook uitsluitend weer op fabrieks en constructiefouten. Nadrukkelijk vermelden wij hier nogmaals dat er geen garantie zit op ontlading of overlading van een accu. Een accu is een verbruiksartikel en bij onjuist gebruik of onderhoud zal een accu eerder defect gaan dan de te verwachten levensduur. Zorg er dus voor dat alle parameters en voorwaarden optimaal zijn om zo lang mogelijk gebruik te kunnen maken voor de AxiWin AGM accu.

Een accu dient ALTIJD bij ons op locatie ingediend te worden voor garantie aanvraag. Transport en levering zijn altijd voor rekening en risico van u als bezitter van de AxiWin AGM accu. Zie voor de garantievoorwaarden ook de Algemene leveringsvoorwaarden waar u mee akkoord bent gegaan tijdens de verkoop. Let op wij geven geen geld retour bij eventuele toegekende garantie. U krijgt altijd een nieuw vervangend exemplaar van hetzelfde type bij toekenning van een eventuele garantie..

Op het meegeleverde aankoopbewijs/ factuur staat de aanschafdatum van de AxiWin AGM accu. U wordt verzocht om het garantiebewijs dan ook goed te bewaren. U kunt natuurlijk ook de aanschafdatum eenvoudig zelf noteren op het acculabel van de AxiWin AGM accu.

Twijfelt u over de juiste toepassing van de accu of zijn er omgevingsomstandigheden die niet in de documentatie voorkomen of Indien u verder nog vragen heeft neemt u dan ten alle tijden direct contact op met onze verkoopafdeling tijdens kantooruren voor de juiste informatie.



Instructions regarding delivery, assembly, use, maintenance and storage of AxiWin AGM batteries

AxiWin or the distributor of the purchased AxiWin AGM product cannot be held liable for problems with the supplied batteries as a result of not correctly following all the instructions provided!

Assembly of the AxiWin AGM battery

Only connect the battery if you understand electronics. Only allow expert and qualified personnel to connect and/or replace the purchased battery! We therefore do not provide any guarantee for consequential damage as a result of incorrect, incompetent and improper use. ALWAYS be well informed and comply with all stated instructions (Including the instructions from the instructions supplied with the vehicle / machine and the associated MSDS (Material Safety Data Sheet). Prevent short circuits, work safely and above all accurately! Most AxiWin batteries are hazardous goods (UN2800). A battery can explode if used incorrectly. Always use (acid) protective clothing and wear goggles when working with or on a battery.

Charging of the AxiWin AGM battery:

Only charge the battery with a good, safe and approved charger. A charger must always be set to the AGM position (see the correct parameters on the enclosed data sheet. NEVER charge the battery in a completely enclosed space. Always ensure a well-ventilated space where smoking and fire are strictly prohibited! Keep away from all cables when charging is taking place. If you do need to touch the battery or charger, make sure that the charger is always switched off. In addition, always prevent fire, sparks, short circuits and friction around and in the vicinity of a battery! and a voltage that is not too low, so charging on time and properly is the motto, and also make sure that the pole connection(s) are always properly "tight".

- The charging voltage of the charger may NEVER exceed 15V and must be at least 14.5 to 14.9 Volt. When an AxiWin battery is fully charged, the charger must ALWAYS go to a float voltage of 13.2 to 13.5 Volt. Check these voltages too!
- If the battery feels hot or gives off an unusual smell, stop charging immediately. Even if the battery changes shape, or if something else abnormal happens, the charging will stop immediately. Let the battery cool down first and (also if in doubt). NEVER load further and immediately consult expert and qualified personnel!
- After charging, let the battery rest for 1 to 2 hours before measuring the voltage. If the voltage is less than 12.4V, additional charging is required. A battery is fully charged when the voltage at rest is 12.8 Volt.
- Never discharge the battery below 12 Volt. Know that a battery below 11.75V is completely discharged. So make sure that the battery is always properly and safely recharged after use. Below 10 Volt the battery is discharged to such an extent that the warranty can NO longer be granted. So make sure that the battery is and remains well charged at all times. Incidentally, most chargers will not even pick up the charge below 7 Volt.

Storage and maintenance of the AxiWin AGM battery:

- Before storage, the battery should be charged to 100%. Then disconnect the battery and store the battery in a clean, dry and well-ventilated room at about 18 degrees. Avoid any contact with corrosive products and NEVER expose the battery to heat, friction, pressure and/or fire.
- During storage, the battery should be regularly checked for voltage and charged if necessary (whenever the terminal voltage is less than 12.4V). Incorrect charge/discharge will cause the battery to malfunction. Sulfate will form in the battery, which will ensure that the battery can no longer hold its current. Sulfation is not covered by warranty! So make sure that the battery is and remains well charged at all times!
- If you opt for a trickle charger or solar panel, make sure that the charger ALWAYS remains connected and is also set to the correct AGM setting. When the battery is fully charged, the charger or solar panel should automatically go to the correct float voltage and when necessary it should also automatically start charging again. Make sure that there is always more current going into the battery than going out. Despite the fact that an AxiWin battery is on a charger or solar panel, it can discharge because, for example, a leakage current or consumer is present. For example, a solar panel does not charge when the sun is not shining and so more power could go out than comes in.

Transport:

- Most lead batteries are hazardous goods (UN2794 or UN2800). Therefore, work safely according to the instructions and according to the MSDS (material safety datasheet).
- The battery must be properly packed. The poles will have to be insulated to prevent short circuits. In addition, a battery must always be secured so that it cannot fall over and/or be damaged.
- A battery should be handled with care. Do not throw the battery and avoid shocks. Never place or mount an AxiWin battery upside down.
- Never transport batteries together with flammable, explosive substances or with sharp metal objects.

AxiWin

Instructions regarding delivery, assembly, use, maintenance and storage of AxiWin AGM batteries

AxiWin or the distributor of the purchased AxiWin AGM product cannot be held liable for problems with the supplied batteries as a result of not correctly following all the instructions provided!

Disposal of the AxiWin AGM battery:

Please think about the environment! AxiWin AGM batteries are 100% recycled and must be disposed of in accordance with applicable environmental legislation. You can always hand over the batteries to us in the Warehouse or to an environmental depot of your municipality. Did you know that you even get some money for the lead in an AxiWin battery when you hand it in to a metal processing company yourself?

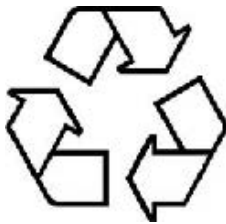

Further:

- Never immerse the battery in water or let it get wet.
- Never store the battery near fire and/or sources of heat.
- Never interchange the positive (+) battery terminal with the negative (-) terminal.
- Never connect the battery directly to a wall socket.
- Never throw the battery into a fire or expose it to a direct heat source.
- Never short-circuit the battery by connecting cables and/or other metals to the positive (+) and negative (-) terminals/battery terminals.
- Never pierce the battery housing with a nail or any other sharp object; never try to break open or step on the battery.
- Never hit or throw the battery and never expose it to strong shocks and/or impacts. Never place and/or mount the battery upside down.
- Never weld directly on or at the battery terminals. Also, do not weld near a battery.
- Never attempt to disassemble or modify the battery.
- Never place the battery in a microwave/microwave oven or in a pressure vessel.
- Never allow the battery to come into contact with corrosive or sharp products.
- Never use the battery together with other types/types/brands of batteries. Certainly not with other types of battery such as dry cell batteries, but also not with batteries that have a different capacity, different production date or are of a different type or brand.
- Never use the battery if it has an unusual smell, feels hot, changes color or shape, or if anything else abnormal happens. If the above occurs while using or charging the battery, immediately remove it from the device or disconnect it from the charger and stop using the battery. Subsequently, always consult expert personnel IMMEDIATELY.
- Ambient temperatures can adversely affect battery performance. Always consult expert and qualified personnel when in doubt about too high or too low temperatures.
- The AxiWin AGM battery is hermetically sealed at the factory, so you may NEVER try to open the battery! The warranty expires IMMEDIATELY when opening a closed maintenance-free battery AxiWin AGM battery. **Garantie:**

An AxiWin AGM type SA & SB comes with a 1-year warranty and then only on factory and construction defects. There is a 2-year warranty on an AxiWin AGM type DC and here again only on factory and construction errors. We emphasize here once again that there is no warranty on discharge or overcharge of a battery. A battery is a consumable item and if used or maintained improperly, a battery will fail sooner than its expected service life. So make sure that all parameters and conditions are optimal in order to use the AxiWin AGM battery for as long as possible.

A battery must ALWAYS be submitted to us on location for a warranty application. Transport and delivery are always for the account and risk of you as the owner of the AxiWin AGM battery. For the warranty conditions, also see the General Terms and Conditions of Delivery that you agreed to during the sale. Please note that we do not give money back with any warranty granted. You will always receive a new replacement of the same type when a warranty is granted.

The supplied proof of purchase/invoice states the date of purchase of the AxiWin AGM battery. You are therefore requested to keep the guarantee certificate in a safe place. Of course you can also easily note the date of purchase yourself on the battery label of the AxiWin AGM battery.

Twijfelt u over de juiste toepassing van de accu of zijn er omgevingsomstandigheden die niet in de documentatie voorkomen of Indien u verder nog vragen heeft neemt u dan ten alle tijden direct contact op met onze verkoopafdeling tijdens kantooruren voor de juiste informatie.

If you are not sure about the correct application of the battery or if there are environmental conditions that are not included in the documentation, or if you have any further questions, please contact our sales department directly during office hours for the correct information.

SAFE HANDLING INSTRUCTIONS	Page: 1 of 7
Lead-acid batteries	Issue date: 1-4-2020 Previous issue date: 21-6-2016

New AxiWin VRLA AGM lead acid batteries are UN2800 non-spillable batteries with Hs code 85072000

SECTION 1. IDENTIFICATION OF THE PRODUCT AND THE COMPANY

1.1 Product identification

Trade name	: Lead-acid batteries
Product definition	: Lead-acid batteries are Articles as defined in Article 3.3 of REACH.
Registration number (REACH)	: Not applicable (no substance with intention to be released).

1.2 Relevant identified uses and uses advised against

Relevant identified uses	: Use the lead-acid battery in line with the instructions provided.
Uses advised against	: This product must not be used in applications other than those recommended in Section 1, without first seeking the advice of the supplier.

1.3 Details of the supplier of the safety data sheet

Importer:	AW ACCU BV Florijnstraat 16, 2988 CL Ridderkerk. The Netherlands +31 (0) 180 531616 sales@awaccu.nl
------------------	--

Supplier:

SECTION 2. HAZARDS IDENTIFICATION

2.1 Hazards

No hazards occur during the normal operation of a Lead Acid Battery as it is described in the instructions for use that are provided with the Battery.

If a separate acid pack is provided with the lead-acid battery, a separate Safety Data Sheet in line with REACH Art. 31 is provided. Please take notice of the hazards and safe use information provided for the acid pack.

2.2 Characteristics

Lead-acid Batteries have significant characteristics:

- They contain an electrolyte which contains diluted sulphuric acid. Sulphuric acid may cause severe chemical burns.
- During the charging process or during operation they might develop hydrogen gas and oxygen, which under certain circumstances may result in an explosive mixture.
- They can contain a considerable amount of energy, which may be a source of high electrical current and a severe electrical shock in the event of a short circuit.
- Standard EN 50272-2 included safety requirements for batteries and battery installations and describes the basic precautions to protect against dangers deriving from electric currents, leaking gases or electrolytes.

2.3 Labelling

The batteries have to be labelled with the symbols listed under section 15.

Lead-acid batteries

Issue date: 1-4-2020

Previous issue date: 21-6-2016

SECTION 3. COMPOSITION AND INFORMATION ON MAIN INGREDIENTS
3.1 Product definition : Article (REACH Art. 3.3)

Chemical name	CAS number	% (w/w) ¹⁾	Hazard statements (CLP 1272/2008) ²⁾
Lead Grid (metallic lead, lead alloys with possible traces of additives)	7439-92-1 ⁵⁾	30-39	Repr. 1A (H360), STOT RE 1 (H272), Acute Tox. 4 (H332), Aquatic Acute 1 (H400), Aquatic Chronic 1 (H410)
Active Mass (Battery Oxide, inorganic lead compounds)	7439-92-1 ⁵⁾	30-39	
Electrolyte ³⁾ (diluted sulphuric acid)	7664-93-9	10-44	Met. Corr. 1 (H290); Skin Corr. 1 (H314)
Plastic Container / Plastic Parts ⁴⁾	-	<10	

- 1) Contents may vary due to performance data of the Battery
- 2) Hazard statements from public data on ECHA website; full text of the hazard statements is listed in Section 16.
- 3) Density of the electrolyte varies in accordance to the state of charge
- 4) Composition of the plastic may vary due to different customer requirements
- 5) Lead is a substance of very high concern (SVHC); listed on the candidate list for authorisation conform article 59 of REACH since 27-06-2018.

SECTION 4. FIRST AID MEASURES

This information is of relevance only if the Battery is broken and it results in a direct contact with ingredients.

4.1 General

- Electrolyte (diluted sulphuric acid) : Sulphuric acid acts corrosively and damages skin.
- Lead compounds : Lead compounds are classified as toxic for reproduction (if swallowed).

4.2 Electrolyte (diluted sulphuric acid)

- Inhalation (acid mists) : Keep calm and quiet, to fresh air. If necessary, provide oxygen or artificial respiration. Seek advice of a medical doctor.
- Contact with skin : Rinse with water. Remove and wash wetted clothing.
- Contact with eyes : Rinse thoroughly with plenty of water for at least 15 minutes. Remove contact lenses, if possible, and continue flushing. Consult a doctor: when eye irritation persists.
- Ingestion : Do not induce vomiting. Drink lot of water immediately and swallow activated carbon. Consult a doctor: if irritation persists.

4.3 Lead and lead compounds

- Inhalation : Inhale fresh air. Seek advice of a medical doctor.
- Contact with skin : Clean with water and soap.
- Contact with eyes : Rinse under running water for several minutes. Seek advice of a medical doctor.
- Ingestion : Wash mouth with water, Seek advice of a medical doctor.

SECTION 5. FIRE FIGHTING MEASURES
5.1 Extinguishing media

- Suitable extinguishing media : CO₂ or dry powder extinguishing agents.
- Unsuitable extinguishing media : Water, if the battery voltage is above 120 V.

5.2 Special protective equipment

- : For larger stationary battery installations or larger stored quantities: protective goggles, respiratory and acid protective equipment, acid proof clothing.

5.3 Advice for fire-fighters

- : When electrical devices are set in fire in general water is the suitable extinguishing agent. For incipient fires CO₂ is the most effective agent. Fire brigades are trained to keep a distance of 1 meter when extinguishing an electrical fire (up to 1 kilo volt) with spray jet and a distance of 5 meter with full jet. For electrical fires in electrical installations with voltages > 1 kilo Volt

SAFE HANDLING INSTRUCTIONS	Page: 3 of 7
Lead-acid batteries	Issue date: 1-4-2020
	Previous issue date: 21-6-2016

other distances are applicable depending on the respective voltage. For fires in photovoltaic installations other rules apply.

SECTION 6. MEASURES TO BE TAKEN IN CASE OF ACCIDENTAL RELEASE

This information is of relevance only if the battery is broken and the ingredients are released.

- 6.1 Personal precautions** : For larger stationary battery installations or larger stored quantities: protective goggles, respiratory and acid protective equipment, acid proof clothing.
- 6.2 Methods and material for cleaning up** : In the case of spillage, use a bonding agent, such as sand, to absorb spilt acid. Use lime / sodium carbonate for neutralisation. Dispose of with due regard to the official local regulations. Do not allow penetration into the sewage system, into earth or water bodies.

SECTION 7. HANDLING AND STORAGE

- 7.1 Precautions for safe handling** : Use the batteries in line with the use instructions provided.
- 7.2 Conditions for safe storage** : Store frost-free under roof in cool ambience. Do not heat charged lead-acid batteries over 50°C. Prevent short circuits. Protect plastic housings against exposition to direct sun radiation. Seek agreement with local water authorities in case of larger quantities of batteries to be stored. If batteries have to be stored, it is imperative that the instructions for use are observed.

SECTION 8. EXPOSURE LIMITS AND PERSONAL PROTECTIVE EQUIPMENT

- 8.1 Electrolyte (diluted sulphuric acid)**
- Possible routes of exposure : Possible exposure caused by sulphuric acid and acid mists during filling and charging.
- Occupational exposure limit values : Source SER database:
 8 h TWA: 1 mg / m³ (Belgium, Netherlands and Spain);
 8 hours TWA: 0,1 mg / m³ (Germany, Austria, Norway and Sweden);
 8 hours TWA: 0,05 mg / m³ (Denmark, Finland, France, UK, EU SCOEL)
 15 min TWA: 3 mg / m³ (Belgium, France and Spain),
 15 min TWA: 0,2 mg / m³ (Austria and Sweden)
 15 min TWA: 0,1 mg / m³ (Finland)
- DNEL / PNEC limit values (REACH public dossier) : DNEL (workers; short term; local effects): 0,1 mg/m³;
 DNEL (workers; long term; local effects): 0,05 mg/m³;
 PNEC (aqua; fresh water): 0,0025 mg/L;
 PNEC (aqua; marine water): 0,00025 mg/L;
 PNEC (Sewerage treatment plant): 8,8 mg/L;
 PNEC (sediment; fresh/marine water): 0,002 mg/kg sediment dry weight.
- 8.2 Lead and lead compounds**
- Possible routes of exposure : No exposure to lead and lead containing battery paste during normal conditions of use.
- 8.3 Personal protective equipment**
- a) Eye/face protection : Wear safety goggles (EN 166)
- b) Skin / hand protection : In case of potential exposure to the electrolyte (diluted sulphuric acid), wear acid-resistant rubber gloves (EN 374), PVC disposable gloves.
- c) Respiratory protection : In case of potential exposure to the electrolyte (diluted sulphuric acid) and insufficient ventilation, wear suitable respiratory equipment (filter type B).

Lead-acid batteries

Issue date: 1-4-2020

Previous issue date: 21-6-2016

- d) Other : Handle in accordance with good industrial hygiene and safety instructions. Wash hands thoroughly after use and before eating or drinking.

SECTION 9. PHYSICAL AND CHEMICAL PROPERTIES

	Diluted sulphuric acid	Lead and lead compounds
Appearance	: liquid (colourless)	solid (grey)
Odour	: odourless	odourless
Solidification point	: -35 to -60 °C	327 °C
Boiling point and boiling range	: 110 – 140 °C	1740 °C
Solubility in water (25 °C)	: complete	very low (0.15 mg/l)
Vapour pressure	: 19 hPa (15-51% H ₂ SO ₄)	not applicable
Density	: 1,10 – 1,4 g/cm ³ (15-51% H ₂ SO ₄)	11,35 g/cm ³

SECTION 10. STABILITY AND REACTIVITY

- 10.1 Electrolyte (diluted sulphuric acid)** : Corrosive, non-flammable liquid. Stable under normal conditions. Thermal decomposition at 338 °C. Reacts with metals producing hydrogen. Reacts violently with alkalis and oxidizing agents. Destroys organic materials such as cardboard, wood, textiles.
- 10.2 Lead and lead compounds** : Stable under normal conditions.

SECTION 11. TOXICOLOGICAL INFORMATION

This information does not apply to the finished product "lead-acid battery". This information only applies to its compounds in case of a broken product.

- 11.1 Electrolyte (diluted sulphuric acid)**
- Acute toxicity : LD50 (oral / rat): 2140 mg/kg
LC50 (inhalation/4uur/rat): 375 mg/m³
 - Corrosion/irritation : High concentrations can cause severe breathing difficulties. When exposed, sulphuric acid vapour or mist may have corrosive effects on mucous membranes, skin and eyes.
- 11.2 Lead and lead compounds** : Lead and its compounds used in a Lead Acid Battery may cause damage to the blood, nerves and kidneys when ingested. The lead contained in the active material is classified as toxic for reproduction.

SECTION 12. ECOLOGICAL INFORMATION

This information is of relevance if the battery is broken and the ingredients are released to the environment.

- 12.1 Electrolyte (diluted sulphuric acid)** : Water polluting liquid that can be toxic to aquatic organisms. Do not allow progression into the sewerage system, soil or bodies of water.
- As described in section 6, use a bonding agent, such as sand, to absorb spilled acid or neutralise using lime / sodium carbonate. Dispose with due regard to local regulations.
- 12.2 Lead and lead compounds** : Are hardly soluble in water. Chemical and physical treatment is required for elimination from water. Lead can be dissolved in an acidic or alkaline environment. Waste water containing lead must not be disposed of in untreated condition

SAFE HANDLING INSTRUCTIONS	Page: 5 of 7
Lead-acid batteries	Issue date: 1-4-2020
	Previous issue date: 21-6-2016

SECTION 13. DISPOSAL CONSIDERATIONS / RECYCLING INFORMATION

13.1 Recycling information

: Spent lead-acid batteries (EWC 160601) are subject to regulation of the EU Battery Regulation and its adoptions into national legislation on the composition and end-of-life management of batteries. Never dispose spent lead-acid batteries with domestic waste. Spent lead-acid batteries are recycled in lead refineries (secondary lead smelters). The components of a spent lead-acid battery are recycled or reprocessed.

At the points of sale, the manufacturers and importers of batteries, respectively the metal dealers take back spent batteries, and render them to the secondary lead smelters for processing. To simplify the collection and recycling or reprocessing process, spent lead-acid batteries must not be mixed with other batteries.

13.2 Other information

: By no means may the electrolyte (diluted sulphuric acid) be emptied in an inexpert manner. This process is to be carried out by the processing companies only.

SECTION 14. TRANSPORT INFORMATION

14.1 Lead batteries, wet, filled with acid

Transport by road/railways (ADR/RID)

: UN number: 2794
 Proper shipping name: BATTERIES, WET, FILLED WITH ACID
 Hazard class: 8
 Remark: New and spent batteries are not subject to the ADR/RID requirements if they meet the requirements of special provision 598.

Transport by sea (IMDG)

: UN number: UN 2794
 Proper shipping name: BATTERIES, WET, FILLED WITH ACID
 Hazard class: 8

Transport by air (IATA-DGR)

: UN number: UN 2794
 Proper shipping name: BATTERIES, WET, FILLED WITH ACID
 Hazard class: 8

14.2 Lead batteries, wet, non-spillable

Transport by road/railways (ADR/RID)

: UN number: 2800
 Proper shipping name: BATTERIES, WET, NON-SPILLABLE
 Hazard class: 8
 Remark: Non-spillable batteries are not subject to the ADR/RID requirements if they meet the requirements of special provision 238 and 598.

Transport by sea (IMDG)

: UN number: UN 2800
 Proper shipping name: BATTERIES, WET, NON-SPILLABLE
 Hazard class: 8
 Remark: Non-spillable batteries are not subject to the IMDG requirements if they meet the requirements of special provision 238 and 598.

Transport by air (IATA-DGR)

: UN number: UN 2800
 Proper shipping name: BATTERIES, WET, NON-SPILLABLE
 Hazard class: 8
 Remark: Non-spillable batteries are not subject to the IATA DGR requirements if they meet the requirements of special provision A67. Provided that poles are secured against short-circuit.

14.3 Lead-acid batteries, damaged

Transport by road/railways (ADR/RID)

: UN number: 2794 or 2800
 Proper shipping name: BATTERIES, WET, FILLED WITH ACID or BATTERIES, WET, NON-SPILLABLE
 Hazard class: 8
 Remark: Packing instruction P801a: transport as dangerous goods (packing

SAFE HANDLING INSTRUCTIONS	Page: 6 of 7
Lead-acid batteries	Issue date: 1-4-2020 Previous issue date: 21-6-2016

in battery boxes) or special provision VV14: transport as dangerous goods (in bulk)

SECTION 15. REGULATORY INFORMATION

15.1 Labelling requirements

In accordance with EU Battery Regulation and the respective National legislation, lead-acid batteries have to be marked by a crossed out dust bin with the chemical symbol for lead shown below, together with the ISO return/recycling symbol.

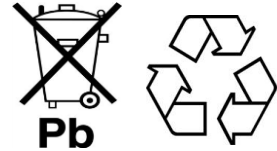

In addition, conform standard IEC 60095-1, lead-acid batteries have to be labelled with the hazard symbols described below.



No smoking, no open flames, no sparks



Corrosive



Wear safety goggles



Observe operating instructions



Keep away from children



Explosive gas mixture

Labelling might vary due to application and dimension of the battery. The manufacturer / importer of the batteries shall be responsible for placing the symbols (a minimum size is specified). In addition, consumer / user information on the significance of the symbols may be attached.

15.2 Authorisation and restriction requirements under REACH

Component	Authorisation list (REACH Annex XIV)	Restriction list (REACH Annex XVII)	Consequences
Lead (EC No. 231-100-4)	Not listed	Listed (entry 63)	Restriction not applicable for lead acid batteries.

SECTION 16. OTHER INFORMATION

16.1 Revision comments

A line in the margin indicates a relevant amendment from the previous version.

16.2 Abbreviations and acronyms used

- Hazard statements (Section 3)
- : H272= May intensify fire; oxidiser.
 - H290= May be corrosive to metals.
 - H314= Causes severe skin burns and eye damage.
 - H332= Harmful if inhaled.
 - H360= May damage fertility or the unborn child.
 - H400= Very toxic to aquatic life.
 - H410= Very toxic to aquatic life with long lasting effects.

16.3 References and sources for data

- : EUROBAT Safe handling instructions (may 2006), ZVEI information leaflet 1e (September 2012), supplier SDSs; public registration dossier ECHA website

16.4 Disclaimer

Products such as Batteries do not require the publication of an EU Safety Data Sheet (REACH Art 31).



SAFE HANDLING INSTRUCTIONS	Page: 7 of 7
Lead-acid batteries	Issue date: 1-4-2020
	Previous issue date: 21-6-2016

The information given above is provided in good faith, is based on existing knowledge and does not constitute an assurance of safety under all conditions. It is the user's responsibility to observe all laws and regulations applicable for storage, use, maintenance or disposal of the product. If there are any queries, the supplier should be consulted.

WAIVING OF LIABILITY: However, the information is provided without any warranty - express or implied - regarding its correctness. The conditions or methods of handling, storage, use or disposal of the product are beyond our control and control and may be beyond our knowledge. For this and other reasons, we do not assume responsibility and expressly disclaim liability for loss, damage or expense be rejected that in any way whatsoever, can result from handling, storage, use or disposal of the product. This safe handling instructions was prepared and is to be used for this product for the identified use only. If the product is used as a component in another product, it is possible that the information in this document is not applicable.

End of document